

RECOMMENDED PLUG

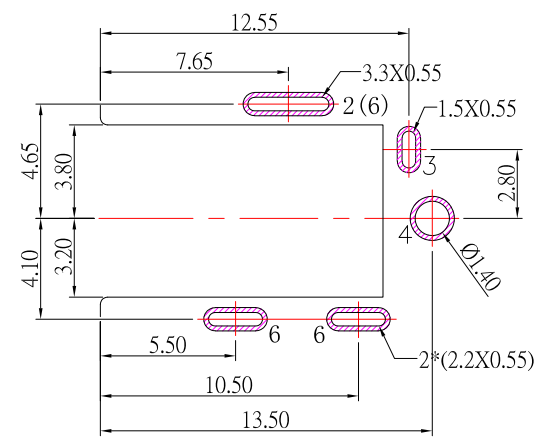

P.C.B LAYOUT TOP VIEW

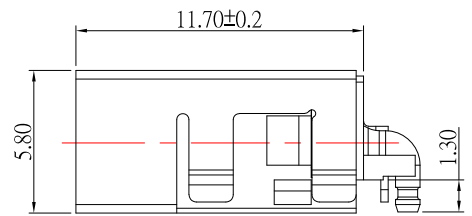
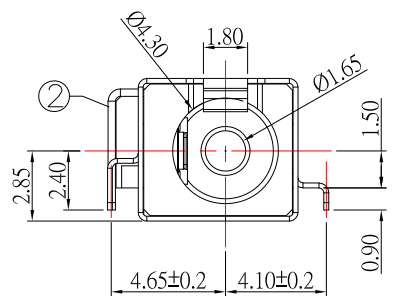
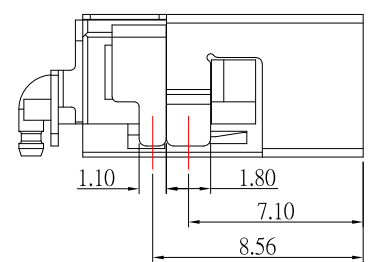

MODEL NO.	DC-D042-1.65
SCHMATIC	

SPECIFICATION

- 1.Rating : DC 20V, 7.0A ;
- 2.Contact resistance : $\leq 30m\Omega$;
- 3.Insulation resistance : $\geq 100M\Omega$;
- 4.Withstand voltage : 500VAC ;
- 5.Insertion and extraction force : 5-30N;
- 6.life test : 5,000 cycles °

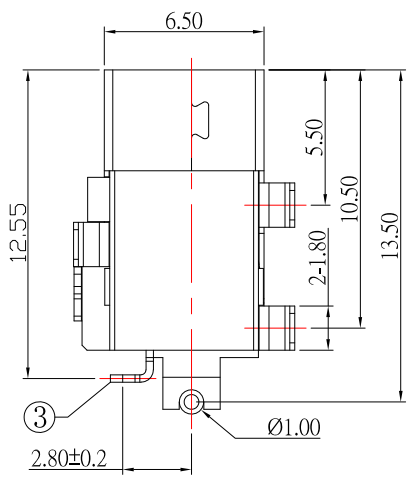
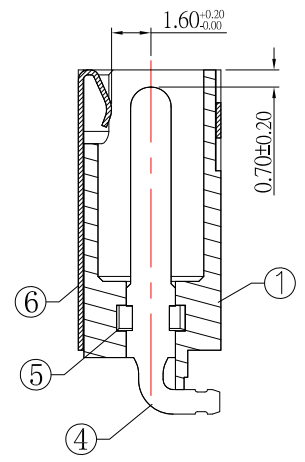

NO.	DESCRIPTION	QTY	MATERIAL	PLATING
⑥	SHELL	1	PHOSPHOR BRONZE	Ni-Plating
⑤	STOPPER	1	PA9T	
④	PIN	1	BRASS	Au-Plating
③	CURVE PIECE	1	BRASS	Au-Plating
②	SPRING PIECE	1	PHOSPHOR BRONZE	Au-Plating
①	HOUSING	1	PA9T	

CONTACT 建倚科技股份有限公司
CONTACT TECHNOLOGY CORP.

TOLERANCE UNLESS OTHERWISE STATED :	Up to 5 ±0.2	3RD. ANGEL'S	UNITS	MM
	Above 5 ~ 15 ±0.3			
	Above 15 ~ 30 ±0.4			
	Above 30 ~ 50 ±0.5			
	Angle ±0.3°			

DRAWN BY:	DATE	MAT'L	TITLE	JACK
Jack Lu	07/19/24			
CHECKED BY:	DATE	FINISH	MODLE	DC JACK
Jacky Chen	07/19/24			
APPROVED BY:	DATE	SCALE	DWG NO.	DC-D042-1.65-S124
Tony Kao	07/19/24	1 : 1		
		SHEET NO.	PART NO.	DC-D042-1.65-S124
		1 of 1		

ITEM NO.	DESCRIPTION	DRAWN	DATE