

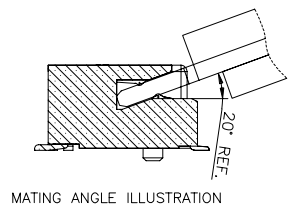

NGF-40S1M-xx-S165

鍍層厚度 :      COLOR :

Blank : 1u"	Black: B
2 : 15u"	White : W
3 : 30u"	

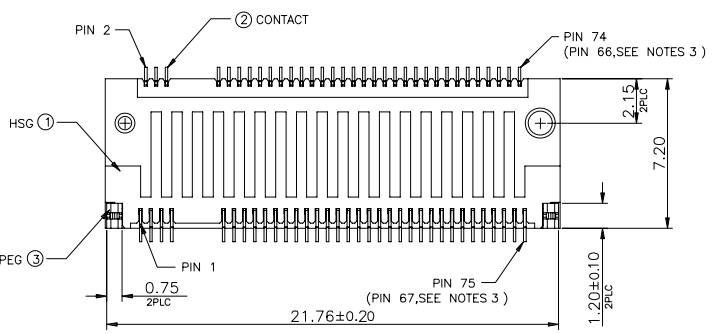
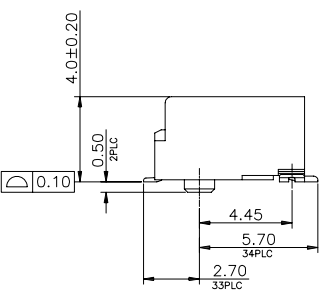
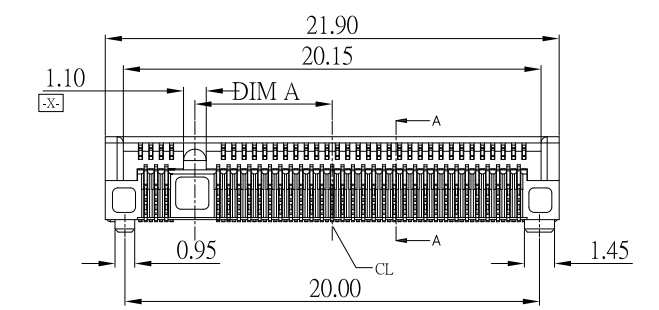
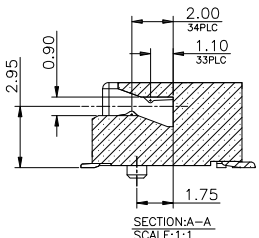
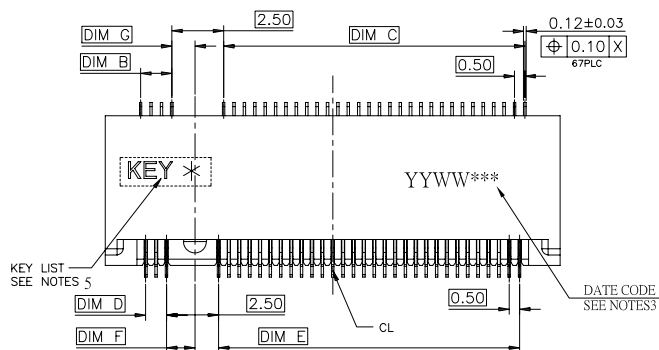

5. Key type & PART NO.:

KEY NAME	DIM A	DIM B	DIM C	DIM D	DIM E	DIM F	DIM G
KEY M	-6.125	14.0	2.0	14.0	1.5	1.125	1.375
KEY L	-5.125	13.0	3.0	13.0	2.5	1.125	1.375
KEY K	-4.125	12.0	4.0	12.0	3.5	1.125	1.375
KEY J	-3.125	11.0	5.0	11.0	4.5	1.125	1.375
KEY H	-2.125	10.0	6.0	10.0	5.5	1.125	1.375
KEY G	-1.125	9.0	7.0	9.0	6.5	1.125	1.375
KEY F	1.625	6.5	9.5	6.0	9.5	1.375	1.125
KEY E	2.625	5.5	10.5	5.0	10.5	1.375	1.125
KEY D	3.625	4.5	11.5	4.0	11.5	1.375	1.125
KEY C	4.625	3.5	12.5	3.0	12.5	1.375	1.125
KEY B	5.625	2.5	13.5	2.0	13.5	1.375	1.125
KEY A	6.625	1.5	14.5	1.0	14.5	1.375	1.125

1.MATERIAL:

- 1.1 Housing: High-Temp Plastic
- 1.2 Contact: Phosphor Bronze
- 1.3 Solder Peg: SUS

2.Finish:

- 2.1 Contact: Plated Gold in Mating Area ;  
Gold Plated on Solder Balls ;  
Nickel under plated overall
- 2.2 Leg: Nickel under plated overall

**CONTACT** 建倚科技股份有限公司  
CONTACT TECHNOLOGY CORP.

TOLERANCE UNLESS OTHERWISE STATED :

Up to 5	±0.2
Above 5 ~ 15	±0.3
Above 15 ~ 30	±0.4
Above 30 ~ 50	±0.5
Angle	±0.3°

3RD. ANGEL'S



UNITS

MM

DRAWN BY:	DATE	MAT'L	TITLE	CONNECTOR
Jack Lu	03/09/22		MODLE	NGFF (M.2) 4.0H M-KEY
CHECKED BY:	DATE	FINISH	SCALE	1 : 1
Jacky Chen	03/09/22		DWG NO.	NGF-40S1M-xx-S165
APPROVED BY:	DATE	SHEET NO.	PART NO.	NGF-40S1M-xx-S165
Tony Kao	03/09/22	1 of 2		

ITEM NO.	DESCRIPTION	DRAWN	DATE

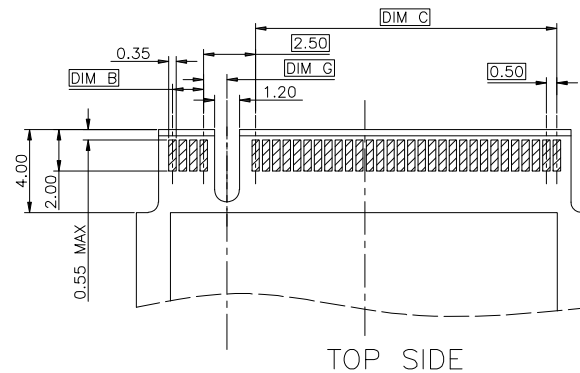
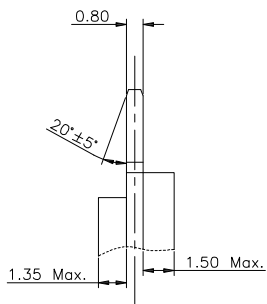
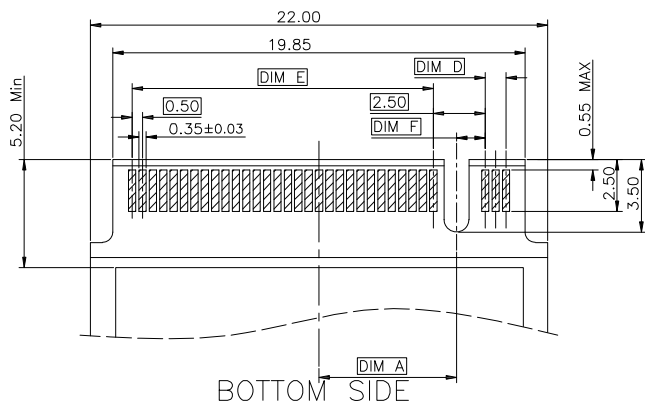

**RECOMMENDED PCB LAYOUT**

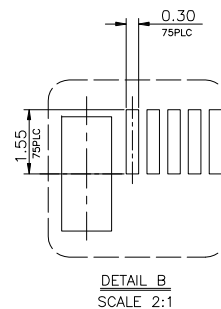
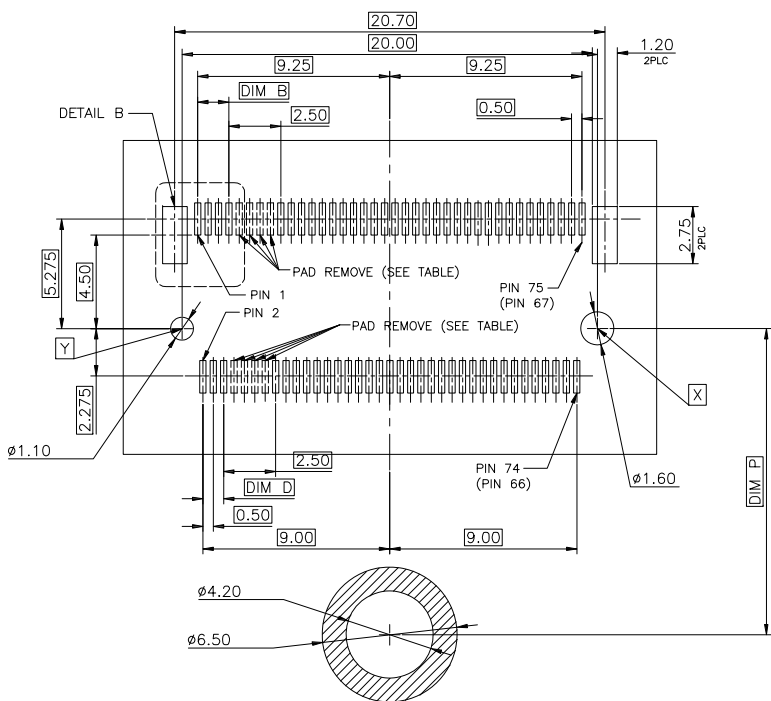

22110	108.25
2280	78.25
2260	58.25
2242	40.25
2230	28.25
3042	40.25
3030	28.25

		MODULE TYPE							DIM P
M	PIN 59-66	-6.125	14.0	2.0	14.0	1.5	1.125	1.375	
L	PIN 55-62	-5.125	13.0	3.0	13.0	2.5	1.125	1.375	
K	PIN 51-58	-4.125	12.0	4.0	12.0	3.5	1.125	1.375	
J	PIN 47-54	-3.125	11.0	5.0	11.0	4.5	1.125	1.375	
H	PIN 43-50	-2.125	10.0	6.0	10.0	5.5	1.125	1.375	
G	PIN 39-46	-1.125	9.0	7.0	9.0	6.5	1.125	1.375	
F	PIN 28-35	1.625	6.5	9.5	6.0	9.5	1.375	1.125	
E	PIN 24-31	2.625	5.5	10.5	5.0	10.5	1.375	1.125	
D	PIN 20-27	3.625	4.5	11.5	4.0	11.5	1.375	1.125	
C	PIN 16-23	4.625	3.5	12.5	3.0	12.5	1.375	1.125	
B	PIN 12-19	5.625	2.5	13.5	2.0	13.5	1.375	1.125	
A	PIN 8-15	6.625	1.5	14.5	1.0	14.5	1.375	1.125	
KEY ID	PAD REMOVED	DIM A	DIM B	DIM C	DIM D	DIM E	DIM F	DIM G	

**CONTACT** 建倚科技股份有限公司  
CONTACT TECHNOLOGY CORP.

TOLERANCE UNLESS OTHERWISE STATED:  
Up to 5 ±0.2  
Above 5 ~ 15 ±0.3  
Above 15 ~ 30 ±0.4  
Above 30 ~ 50 ±0.5  
Angle ±0.3°

3RD. ANGEL'S



UNITS MM

DRAWN BY:	DATE	MAT'L	TITLE	CONNECTOR
Jack Lu	03/09/22			
CHECKED BY:	DATE	FINISH	MODLE	NGFF (M.2) 4.0H M-KEY
Jacky Chen	03/09/22			
APPROVED BY:	DATE	SCALE	DWG NO.	NGF-40S1M-xx-S165
Tony Kao	03/09/22	1 : 1	PART NO.	NGF-40S1M-xx-S165
		SHEET NO.	2 of 2	

SIZE A4  
VER R