

P.C.B. LAYOUT

SPECIFICATIONS

Rating	DC 12V 50mA
Contact Resistance	100mΩ Max.
Insulation Resistance	50MΩ Min.
Travel	0.2 ± 0.1mm
Operating Force	160 ± 50gf
Operating Life (cycles)	70,000

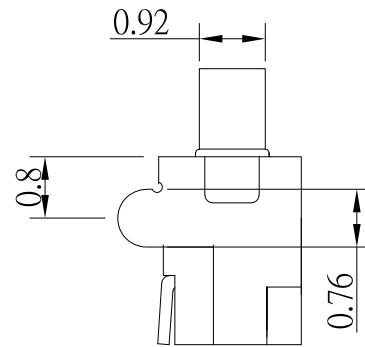
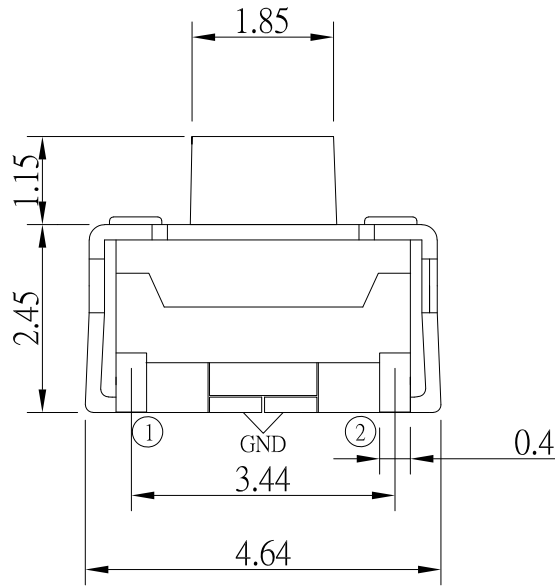

NO.	DESCRIPTION	QTY	MATERIAL	PLATING
E	TERMINAL	2	PHOSPHOR BRONZE	Ag plated
D	CONTACT	2	SUS	Ag plated
C	COVER	1	PHOSPHOR BRONZE	Ag plated
B	BASE	1	PA6T	Black
A	STEM	1	PA6T	Black

ITEM NO.	DESCRIPTION	DRAWN	DATE
8	新增Travel	Jack	010625
7	更新Operating Force	Jack	043019
6	更新樣式	Jack	041619

CONTACT 建倚科技股份有限公司
CONTACT TECHNOLOGY CORP.

TOLERANCE UNLESS OTHERWISE STATED :

Up to 5	±0.2
Above 5 ~ 15	±0.3
Above 15 ~ 30	±0.4
Above 30 ~ 50	±0.5
Angle	±0.3°

3RD. ANGEL'S

UNITS MM

DRAWN BY:	DATE	MAT'L	TITLE	SWITCH
Jack Lu	01/06/25	FINISH	MODLE	TACT SWITCH
CHECKED BY:	DATE	SCALE	DWG NO.	TS-A00AD-2-S246
Jacky Chen	01/06/25	1 : 1	PART NO.	TS-A00AD-2-S246
APPROVED BY:	DATE	SHEET NO.	1 of 1	
Tony Kao	01/06/25			

SIZE A4
VER R8